

# PrimeFire in Casing

Enjoy natural flames without smoke, smell or ash

## FEATURES

- BEV\* Technology - no contact between fuel and flame
- Automatic refill system
- LED Control panel
- Advanced safety sensors
- 2 levels of flame height
- Possibility of joining modules
- Possibility of remote service in case of errors
- No hard connection required
- Optional remote control
- Optional frame



## TECHNICAL DATA

PrimeFire in Casing	
Capacity	2,0 L / [US] 0,5 gal / [UK] 0,4 gal
Burning time	4,0 - 6,5 h
Heat output	1,9 - 3,1 kW / 6839 - 10648 BTU
Net weight	18 kg / 40 lbs
Air circulation	min. 1/h
Minimum room size	31,2 m <sup>3</sup> or please contact our Project Department for details
Power supply	230 V
Finish	FIREPLACE: black powder coating CASING: black powder coating OPTIONAL FRAME: black powder coating

## DIMENSIONS

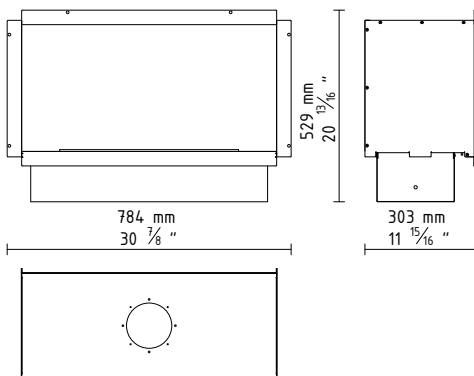

## INSTALLATION REQUIREMENTS

