

PrimeFire Logs in Casing

Enjoy natural flames without smoke, smell or ash

FEATURES

- BEV* Technology - no contact between fuel and flame
- Automatic refill system
- LED Control panel
- Advanced safety sensors
- 2 levels of flame height
- Possibility of joining modules
- Possibility of remote service in case of errors
- Ceramic logs, decorative granulate and small front glass included
- No hard connection required
- Optional remote control
- Optional frame



TECHNICAL DATA

PrimeFire Logs in Casing	
Capacity	2,5 L / [US] 0,66 gal / [UK] 0,55 gal
Burning time	5,0 - 8,0 h
Heat output	1,9 - 3,1 kW / 6839 - 10648 BTU
Net weight	19 kg / 43 lbs
Air circulation	min. 1/h
Minimum room size	31,2 m ³ or please contact our Project Department for details
Power supply	230 V
Finish	FIREPLACE: black powder coating CASING: black powder coating OPTIONAL FRAME: black powder coating

DIMENSIONS

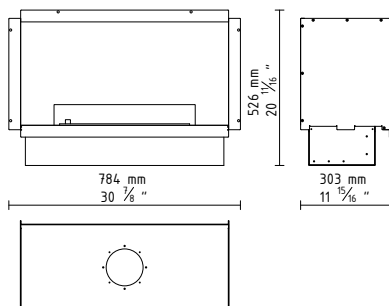

INSTALLATION REQUIREMENTS

